

SAE Sure-Grip® L Series Flangeless Bushings

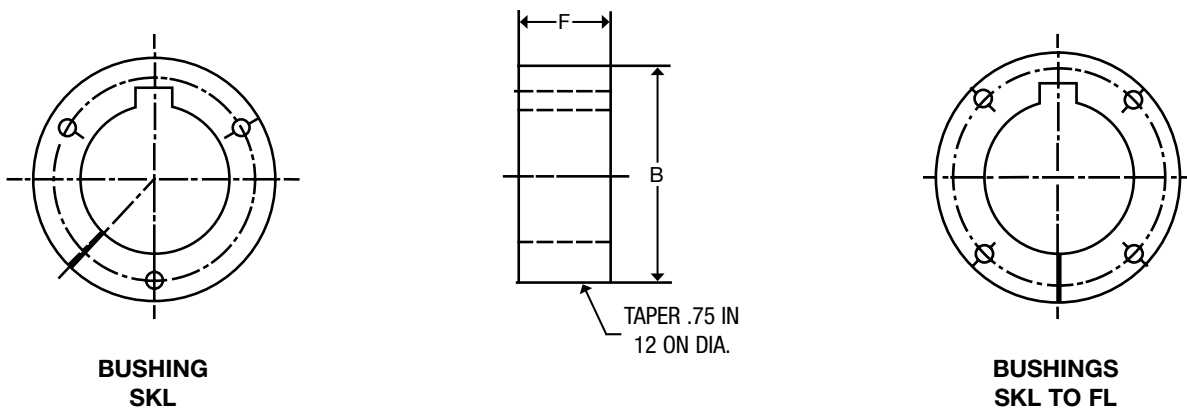

Bush.	Torque Capacity (In.-Lbs.)	Type Material	Max. Bore (In.)	Max. Bore (In.)	DIMENSIONS IN INCHES		Bolt Circle	Cap Screws Required
					B	F		
SKL	7,000	D.I.	1-15/16	50	2.8125	1-1/8	2-3/8	3-1/4 x 1-3/4
SFL	11,000	D.I.	2-3/8	60	3.1250	1-1/8	2-3/4	4-1/4 x 1-3/4
EL	20,000	D.I.	2-7/8	73	3.8340	1-1/2	3-3/8	4-5/16 x 1-3/4
FL	45,000	D.I.	3-1/8	80	4.4375	2-3/8	3-3/4	4-3/8 x 2



Patent No. 5304101

To Install:

IMPORTANT: DO NOT USE LUBRICANTS IN THIS INSTALLATION

1. Inspect shafts, bushing, and mating hub. Remove all nicks, paint, dirt, grease, etc. from mating surfaces.
2. Place key in shaft's keyseat.
3. Slide bushing onto shaft and key. **Small End of Taper Must Be Outboard.**
4. Slide tapered mating hub over bushing. Align (1) the shaft key with one of the slots in the mating hub and (2) the drilled holes in mating hub with the threaded holes in the bushing.
5. Put lockwashers on cap screws and insert one cap screw thru each drilled hole in the mating hub and into the threaded hole in the bushing.
6. **Use a Torque Wrench.** Tighten all cap screws evenly and progressively in rotation. Torque around all the cap screws as often as necessary until the listed torque value remains on each cap screw.

Bushing	Torque (Ft.-Lbs.)
SKL	15
SFL	15
EL	30
FL	55

CAUTION
The use of lubricants or excessive wrench torques may cause hub stresses high enough to break the mating hub!

To Remove:

1. Loosen and remove all cap screws from assembly.
2. Install one cap screw in each threaded hole in the mating hub.
3. Evenly torque each cap screw in rotation to force the mating hub off the bushing.